

Coin-operated Breath Alcohol Tester

AT319 Operation Manual

Notification

1. To ensure the real test result of alcohol concentration, please wait 15 minutes to take test after drinking.
2. If noise gas with high concentration existed, may the tester won't work normally.
3. The result may be unreliable for your first test if long time storage, please try again for several times.
4. No cigarette smoke direct into tester.
5. Please use matched accessories.
6. Avoid any fall or strong shock.

7, How to change the sensor module

The Sensor-module design makes it no necessary to calibrate tester. Just change new module when the tester displaying **0000** sparkingly. Each module can be used for 1000 times.

- Turn off the tester, then open its front panel, you can see a grey shell with pipe and connector, it's the sensor module.
- First you take off the pipe and connector, then screw the thread by counter clockwise, now the sensor module have been take off.
- Then take a new sensor module, and first screw the thread by clockwise, then connect the pipe and connector, it's OK now.

8. Notification

- 8.1. Avoid any fall or strong shock.
- 8.2. If noise gas with high concentration existed, may the tester won't work normally.
- 8.3. To ensure the real test result of alcohol concentration and avoid sensor damage, please wait 15 minutes to take test after drinking.
- 8.4. The result may be unreliable for your first test if long time storage, please try again for several times.
- 8.5. Do not keep the tester in the environment of Corrosive gas (Chlorine etc) for use or deposit.
- 8.6. The life of sensor is over 2 years under standard use in the normal environment.
- 8.7. If need to clean the tester, please use the soft wet cloth or appropriate neutral scour, do not use the organic solvent to clean the tester surface.

6), The result will be displayed on the screen for several seconds, then the LCD turns to normal wait state again, the user can take test for the next time.

Testing result type	Alcohol tester staus	
	Indication LED	Buzzer
OK (lower than warning level)	OK LED on	soft “di-di di” sound
Warning (between the warning and danger level)	Warning LED on	“di-di di” sound
Danger (reach or exceed the danger level)	Danger LED on	Hurried “di-di di” sound

Table 5

6, Normal fault and solutions

Table 6

Fault	Possible reason	Solution
No display on LCD	Unstable power cord connec	Plug in again
	Circuit fault	Contact distributor
No response to detection gas	Gas entrance jam	Wipe off the jam
	Circuit fault	Contact distributor

Table of Contents

1.DESRIPTION.....	1
2. MAIN TECHNIC DATA	1
3. INSTALLATION MANUAL	错误！未定义书签。
4. PREPARATION BEFORE USAGE.....	3
4.1SET UP THE TEST UNIT	3
<u>4.2 SET UP THE COIN QUANTITY.....</u>	<u>4</u>
<u>4.3 SET UP THE MODEL COIN.....</u>	<u>4</u>
5. TEST PROCEDURE	错误！未定义书签。
6. NORMAL FAULT AND SOLUTIONS	7
7.HOW TO CHANGE THE SENSOR.....	8
8. NOTIFICATION.....	8

1.Description

AT319, coin-operated Breath Alcohol Tester, is designed to measure alcohol concentration in the human body. With advanced fuel cell alcohol sensor, this device has excellent sensitivity and reproducibility. Reasonable and easy testing process, complete function make it versatile in many occasions. When the alcohol content exceeds the preset alarming level, it will send out an alarm warning and show the result directly and clearly on the digital LCD display.

2.Main Technical Data

Model	AT319
Sensor type	Fuel cell sensor
Test Range	0.000~4.000g/L (0.000~2.000mg/L、 0~440mg/100mL、0.000~0.400%BAC、 0.000 ~ 0.400g/100mL 、 0.000 ~ 2.000‰BAC)
Resolution	0.002g/L
Preheating time	≤1min
Warning level	0.180g/L
Danger level	0.500g/L
Environment	Temperature: 0℃~50℃; Relative humidity: ≤95% No Dews
Storage temperature	-20℃~60℃
Display	Four digits LCD display; Test process and result are showed by the red, green, and yellow indicator light
Warning method	Audio and light
Working Voltage	Input: AC100V~AC240V, 50/60HZ; Output: DC12V/1.5A

buzzer ring, the indication LED will turn on then off in turn, this is checking the buzzer and indication LED is working normally or not; The LED screen will show “aa b” and “cccc” in turns (aa means the coin quantity should be inserted, b means the measuring unit, cccc means the tests No.s of sensor module have been made).

when “Wait” indicator light twinkles, it begins to warm up but can't take test at this time. About 6 seconds later, the initialization finishes and test can begin, meantime, < Insert straw > indicator light illuminates, <Insert coin> light twinkles and prompt to throw coin and start to test.

2), After the initialization is finished, the tester enters into normal testing procedure. If the coin quantity is set as 0(it means no necessary to insert coin), now the “insert straw” LED is on, please follow the step 4 to continue operation; If the coin quantity is set not 0, now the “insert coin” LED illuminates, please follow step 3) to insert coin.

3), Insert coin: The coin could be inserted when <INSERT COIN > LED flash, the coin quantity and value is up to the model coin initial enactment. For more coins insert, the tester will send out “di” for each coin and show the necessary remanent quantity on screen. When the coin reaches up to the quantity of initial setting, <Insert coin> LED is off, <Blow> LED twinkles and test can be started.

4), Take the straw from straw box, insert the straw, please have a deep breath, then blow to tester continuously and equally, don't stop until the prompt tone sounds. If the user stops blowing during the test, the device will send out “di---di di” sound to remind “breath interrupt”. The user should blow again till the blowing finishes after the “di---di di” stopped.

5),The result on the LCD screen shows the alcohol concentration in the user's body when the test finishes.

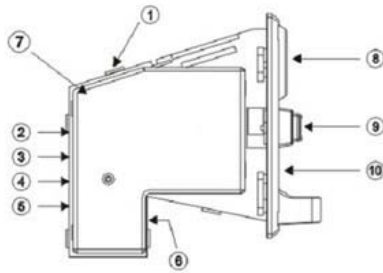

Pic 4

Function and position explanation:

Table 4

Name	Function
① 3 segment jiggle switch	Distinguish accuracy: exact, normal, loose
② 4 pin Jack	
③ 2 segment jiggle switch	Distinguish NO and NC
④ 3 segment jiggle switch	COIN single transmission speed: fast, middle and slow
⑤ Jiggle button	SET button
⑥ 2 pin Jack	Electromagnetic strobe
⑦ LED Indication	Showing to set the coin
⑧ Coin entrance	Coin Entrance
⑨ Coin return button	Press this button to get the coin which blocked in the coin entrance
⑩ Coin returned exit	Coin returned exit

5, Alcohol concentration detection

Test procedure:

1), Power on the tester, it begins to initialize firstly, along with

Indication manne	g/L 、 mg/L、 mg/100mL、 %BAC (g/100mL)、 %BAC optional
Accuracy	±8%
Coin for single time	0 —— 15 (For 0, the tester can be tested without coin)
Coin diameter	15mm~29mm
Coin Thickness	1.8mm~3.0mm
Coin capacity	200pcs
Straw box capacity	200pc (outside diameter is about 7mm)
Sensor lifespan	2 years
Dimension	250mm×105mm×400mm
Weight	About 4kg

3. Part name and Installation manual

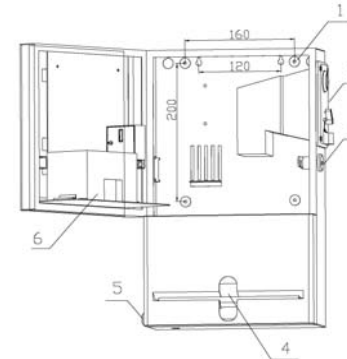

- 1 screw hole
- 2 coin selector
- 3 lock
- 4 straw exit
- 5 On/Off switch
- 6 coin box

Pic 1

Firstly please find a right place then fix the device on the wall (see Pic 1) by using the bolt packed along with the device. Or the tester can be put directly on the platform for use.

4. Preparation before use

4.1 set up the test unit



Note: Please cut off the power supply before operation

Note: Please cut off the power supply before operation

There are mg/l、mg/100ml、g/l、%BAC and ‰BAC optional, user can set the test unit through Dial switch S2 which is inside of the device. Make sure the unit set is same with the unit shown on its front panel.

The test unit is set by dialing the first to the third switch. It means 1 when the switch is dialed on the top, 0 at the bottom. (Note: It is of no effect for the 4th switch)

For example, in Pic 2 below, both the first and third switch are dialed at the bottom (they mean 0 separately); the second switch is dialed on the top (it means 1). So, according to the Table 1, current unit is g/l.

“mg/l” is the default test unit before the device leaves factory

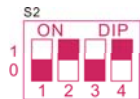

Pic 2

A	B	C	D	Unit
0	0	0	×	mg/L
0	0	1	×	mg/100mL
0	1	0	×	g/L
0	1	1	×	%BAC (g/100mL)
1	0	0	×	‰BAC

Table 1

“g/l” is the default test unit before the device leaves factory.

4.2 Set up the coin quantity



Note: Please cut off the power supply before operation

The coin quantity is set by Dial switch S1 inside of the device. It means 1 when the switch is on the top, 0 at the bottom.

Setting quantity range: 0-15pcs.

For example, in Pic 3, both the first and third switch are at the bottom (they mean 0 separately); the second and fourth switch are on the top (they mean 1 separately). So, according to the Table 2, you will need 5pcs coin to go ahead to test alcohol concentration.

1pc coin is the default coin quantity before the device leave factory.

Table 2

A	B	C	D	Coin Qty
0	0	0	0	0
0	0	0	1	1
0	0	1	0	2
0	0	1	1	3
0	1	0	0	4
0	1	0	1	5
0	1	1	0	6
0	1	1	1	7
1	0	0	0	8
1	0	0	1	9
1	0	1	0	10
1	0	1	1	11
1	1	0	0	12
1	1	0	1	13
1	1	1	0	14
1	1	1	1	15

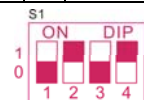

Pic 3

4.3 How to set up the model coin

Power on the tester, open the front door, you can see ⑦LED indicator lamp lighting continuously. Press jiggle button⑤ and hold it until the indicator lamp flash slowly, then press the jiggle button⑤ again till the indicator lamp turns to flash quickly, now please put 20 model coins into the coin slot(Recommend to put into coins of different years with different versions, coins must be fast or slow speed so as to simulate the normal use.) When you are finished, the indicator lamp remain constant lighting.