

GUMBALL MACHINE OPERATING INSTRUCTIONS

(FOR THE 9" MACHINE ONLY)

• **TO FILL MACHINE:**

Unscrew the screw plug and remove the cap. Pour the gumballs carefully into the glass globe.

• **REMOVAL OF COINS :**

Remove screw plug, cap, nut, retaining ring, glass globe, brush plate, and adjustable wheel. Grasp body and lift up to reach coins.

• **TO OPERATE MACHINE:**

Place coin into slot on face plate/coin receiver and turn handle one revolution. For dispensing without using coins, lift coin mechanism upward from its position, then unscrew and remove brass colored restraining arm on back of coin mechanism.

• **MAXIMUM GUMBALL DIAMETER IS 15 mm.**

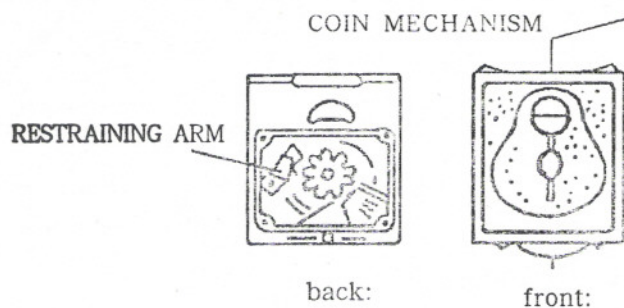
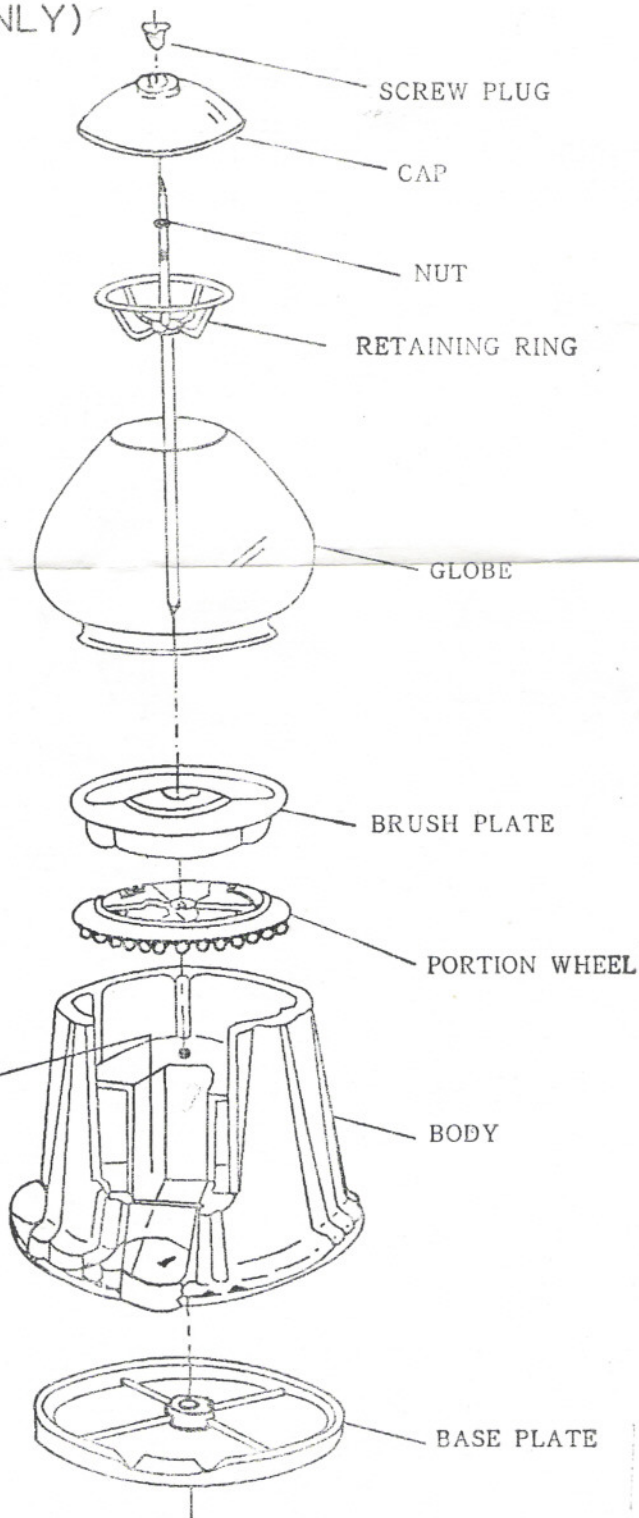

CAUTION: DO NOT OVER TIGHTEN TOP SCREW PLUG

Made and Printed in China