

Characteristics



HV-301R/RD



Design of High Quality

Superb design of thick cafe atmosphere and smooth, grace, elegant streamlined appearance.



With Mineral Water Tank

Designed to use the mineral water tank to avoid the trouble to pour in water from time to time.



Automatic Flavoring

Advanced flavoring setting taste with microcontrol.



Automatic Coin Recognition Device

One-yuan coin can be used.



Adjustment of Hot Water Temperature

The temperature inductor is installed in the heating cabinet and the water temperature can be adjusted to 80°C - 93°C



Big-Volume Raw Tank

The big-volume tank is used, which can be compared with the large slot machine.



Big Load of Paper Cups

paper cup loading is the first among the similar products.



Convenient Cleaning of Exhaust Fan

The hook for easy cleaning is designed in the curve way and frequent exhausting may extend the lifetime of the machine.

Specification

Model:	HV-301R/RX
Power:	AC220/240v 50Hz
Water Tank Volume:	4L
Hot Water Volume:	1.6L
Cup Loading	About 110
Display:	LED&FND
Coin	One-yuan coin
Size: (W*D*H)	440*530*650
Raw material:	Instant coffee Choco Cappuccino powder
Weight:	23kg

Contents

Characteristics, Specification	1
Placement	3
Warning and Caution Marks	4
Work Before Use of Machine	7
Description of Elements & Parts	8

Before Use

Introduction of Button on Operation Panel	9
Display Function Instructions	10
How to use the Mineral Water Container	11
How to Place Raw Material	12
How to Fix the Raw Material Bucket	13
How to Place the cups	14
Setting and Usage	15
Adjustment of Taste/Water Volume	16
Setting of Unit Price	17

How to Use

Setting for Water Temperature	18
Sales Quantity Confirmation function	19
Defect Confirmation	20
Dismantling of Parts	21
Cleaning	22
Warranty Card	23

Others

Placement

Do not place in the following place:

- 1 The slanting surface or uneven place.**
Please place the machine in plain place

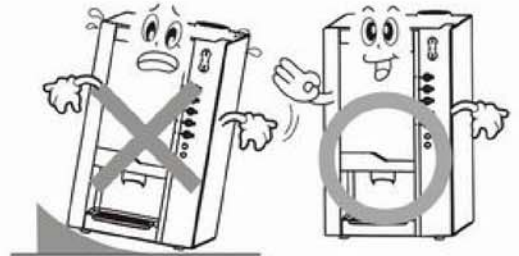

- 2 The dangerous place.**
Avoid the place of fire danger.



- 3 The place under direct light or rain and wind.**
Please place it where there is no direct light and wind and rain.



- 4 The noisy place.**
Place it far from electrowaves and noise.

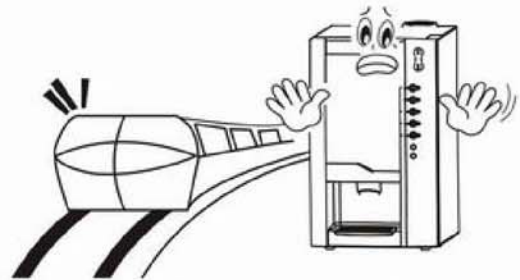



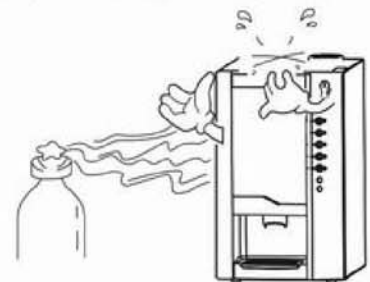









- 5 The place where there is sea wind (humid) or toxic gas:**
Place it where is no influence.



Warning and Caution Marks

Safety is divided into warning and caution:

 Warning This mark shows that violation of the requirements of operation may cause death or severe injury.	 Caution This mark shows that violation of the requirements of operation may cause injury of human body or damage of house and other property.
 This mark shows that violation of the requirements of operation may cause death or severe injury.	 This mark shows that if put near inflammable gas or volatile, there is danger of explosion.
 will cause danger to remind probably.	 This mark shows that there is danger of electric shock.
 This mark show power plug is pulled out.	 This mark shows that one should not touch the hot spot.
 This mark shows impossibility of dismantle.	 This mark shows one should not touch functional positions.
 This mark shows to touch with the bare hand is not allowed.	 This mark shows if one does not use the nominal power, there is danger of fire.



Warning

When pouring water into the water tank, avoid spilling or leaking inside or onto the side of machine.

• Otherwise electric shock or fire may occur.

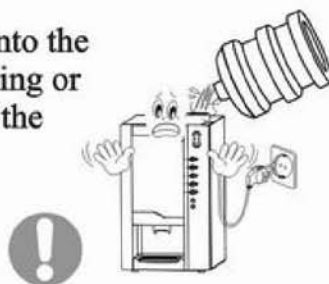

Do not pull or plug the power line with wet hand.

• Danger of electric shock.



Do not touch



Avoid weighting down and damaging the power line.

• Danger of electric shock or fire because of electricity leak. Please use specific power socket.

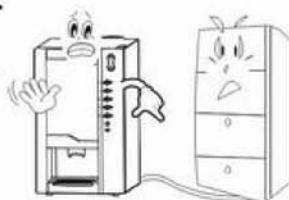

Do not connect several appliances to use socket.

• It may be cause of fire.



Forbid









Warning and Caution Marks

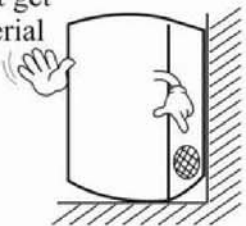

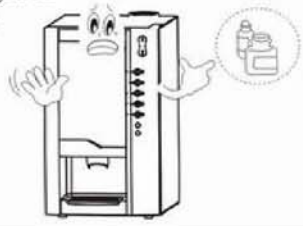
Caution

Before Use

<ul style="list-style-type: none"> Do not give too much pressure onto the front operation position, otherwise deterioration of machine occurs.  <p>Forbid</p>	<ul style="list-style-type: none"> Do not place the machine too close to the wall, otherwise there is poor exhaustion. If humid inside the machine does not get out, the raw material may solidify.  <p>Forbid</p>
<ul style="list-style-type: none"> Do not pull the power line for it may cause electric leak or shock by the damaged part of the line.  <p>Forbid</p>	<ul style="list-style-type: none"> Do not place the machine opposite of the air-conditioner. It may be one of the causes of solidification of raw material.  <p>Forbid</p>
<ul style="list-style-type: none"> Except for instant powder material, do not use other material. Usage of particles or sticky raw material such as peanut, tea, soup, gruel etc. for it may stop up the connecting passage.  <p>Forbid</p>	<ul style="list-style-type: none"> Do not put your hand into under the bottom of the machine for it may cause injury by a sharp-edged.  <p>Do not dismantle</p>
<ul style="list-style-type: none"> When the machine is out of use for a long time (over 2 days), please pull out the plug. Otherwise it may cause fire because of overheating.  <p>pull out the plug</p>	<ul style="list-style-type: none"> If there is alien sound or smell, pull out the plug at once and contact with the sales center or the owner of store.  <p>pull out the plug</p>

Warning and Caution Marks



Warning

- Do not twist or pull or damage the power line. It will break the line and it is very dangerous.



Forbid

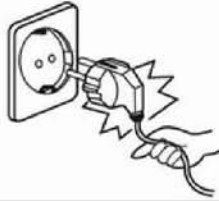

- Do not put utensils with water on the top of the machine. The dripping water will decrease insulation and cause electric shock and fire.



Forbid



- Do not put the machine in the humid place, otherwise insulation of electric articles may deteriorate and cause electric shock and fire.



Forbid



- When replacing the fuse, pull out the power plug, otherwise there is danger of electric shock.



Pull out plug

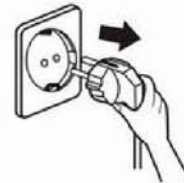

- Please use a special socket of 220V. If the machine is used in the area of 110V, please use a step-up transformer in conformity with the capacity. If the designated transformer is not used, there is danger of fire and shock. The step-up transformer is to be bought separately (over 2KVA).

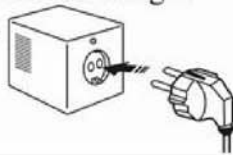

- Do not dismantle the machine, or it may cause shock or damage.



Do not dismantle



- Clean the metallic part of the power plug of the alien matter, or it may cause fire.



- When you find out that the hoses of socket are loosened, do not put the plug in, or it may cause shock and fire.



Forbid

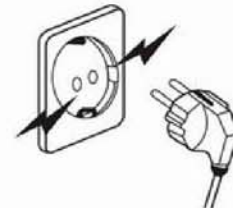

Work Before Use of Machine

- 1** Clean the machine. Connect the water box. Connect the earth wire (green). Connect the earth bar.
 * Clean inside and outside of the raw material tank.
 * About cleaning, see page 18.



- 2** Place the machine from the wall at least 10cm and choose the even floor. The uneven floor is one of causes of noise and poor working.

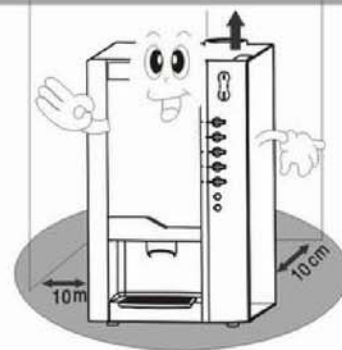

- 3** Put the water box to the former place.

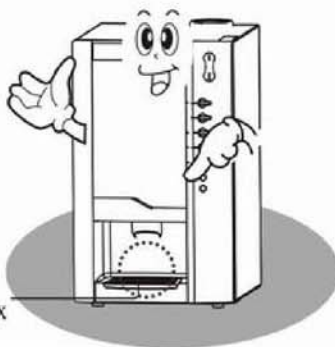

Connect the water box

- 4** For the safety sake, please use a special socket with earth wire.
 *If you do not use the socket with earth wire, please connect one end of the wire (green, a copper wire over 1.6mm or soft wire over 1.25mm or over 2mm) and the other end to copper plate or earth bar and bury it 30cm deep. Be sure not to connect the wire to the pipe of LPG. It is very dangerous.

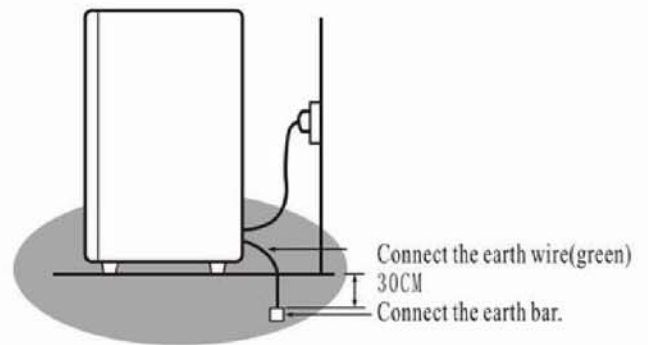

Before Use

Accessory

2 keys	Operational manual /warranty card	Coin box	Water receptacle	Water tank outlet	4raw material tanks	3raw material bucket

Description of Elements & Parts HV-301R/RD

● Front Side

● Back Side

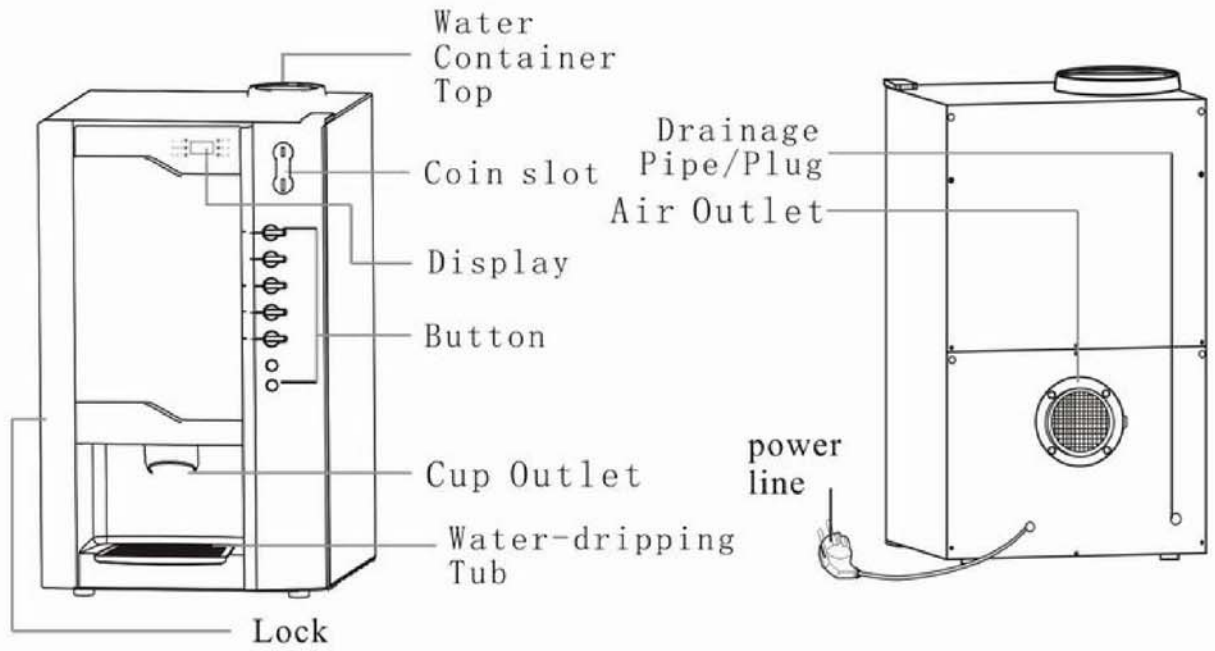

● Inner Side

● Inside the Cabinet Door

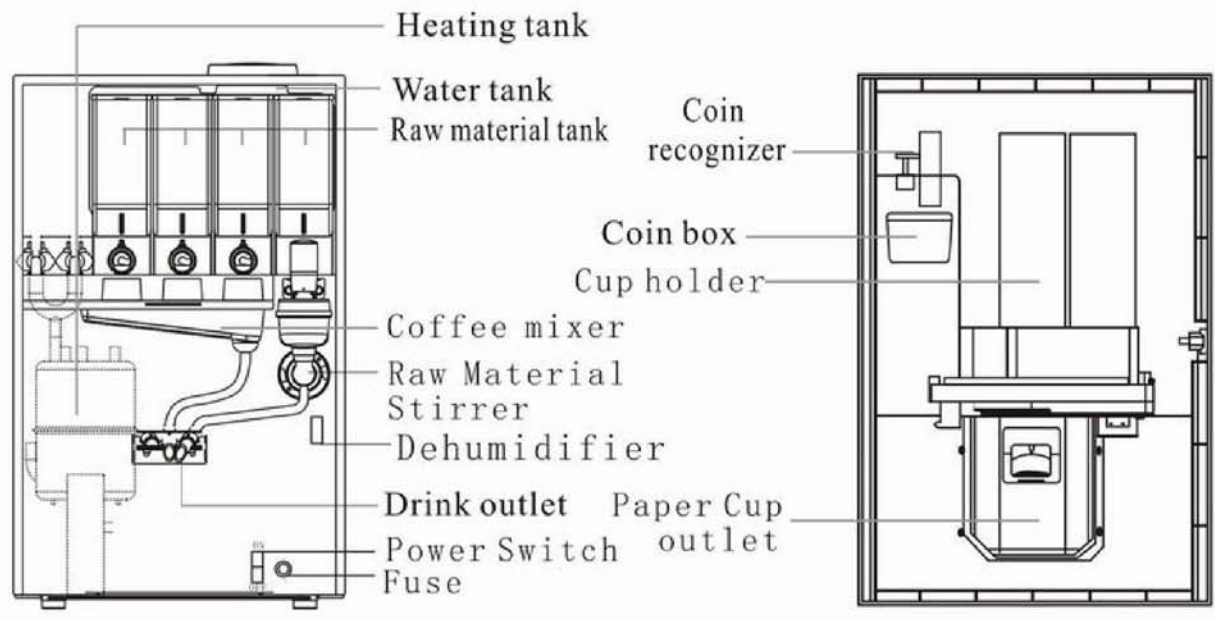

Introduction of Button Function on Operation Panel

● Operation Panel

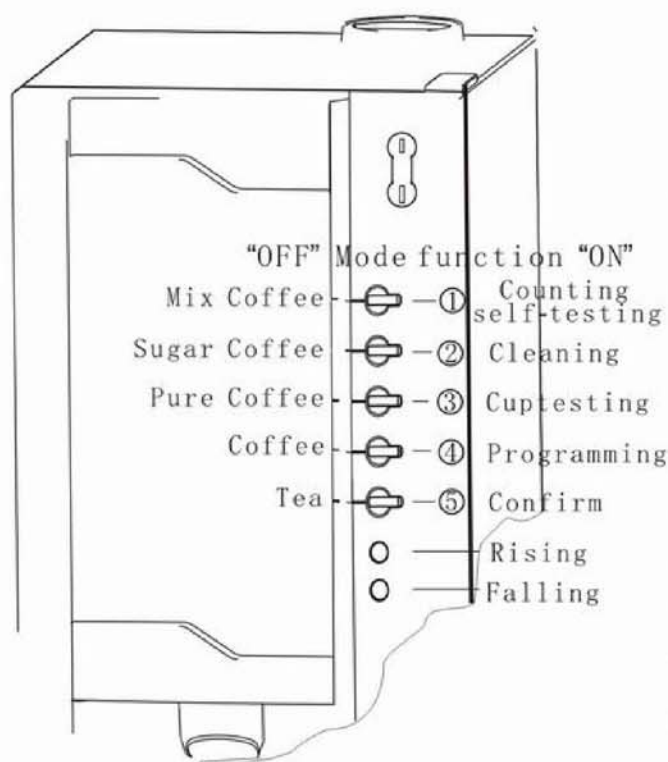

Self-checking Function

There is self-checking function with this Coffee machine. Turn the Mode Function switch (inside the machine) to position "ON", Display shows " E E E " and the machine is in stand mode. Then press No.1 button once and display shows " E E E "(means checking).

Press No.5 button (Confirm Function button) here and the machine starts to operate self-checking.

Checking sequence is as follows:

Water supply solenoid valve, cups holder electromagnet (Next item will be checked if there is no cups holder with machine),

water pump under the Water Container (only for those coffee machine with the water Container at the bottom) Stirrers, mixing motor3, mixing motor2, mixing motor 1, material feeding motor3, material feeding motor2, material feeding motor1.

Customer can clearly look over the running status of above components, to judge whether it

works in good condition or not.

Caution: 1. Self-checking should be operated before filling the material box and usually with the material box dismounted.

2. Pick the water at the drink outlet with a vessel.

Display Function Instructions

● Display (as following chart) Function Instructions



“Digital Display” made of three digital tubes is mainly display the machine’s digital information for current state of settings or working. There are two LED at the both sides of the digital display. When the digital display shows the unit price of drinks, LED beside the “Unit Price” lights up and as well LED of “Unit Prices” and “Be Heating” will lights up when plug in the power and the heater becomes to work. For at this time the hot water temperature for drink is not enough high, the Coffee machine is in Standby Mode (when insert coin or press the drink button at this time, the coin will be return to the customer and the Coffee machine refuses to serve drinks). Heating needs about 13~15 minutes and then LED of “Be Heating” will lights off and LED of “ For Use ” lights up which means the coffee machine is in working state.

When no cups in the machine, LED of “No Cup” will lights up and buzzer starts to alarm so as to awake owner. (When insert coin or press the drink button at this time, the coin will be return to the customer and the Coffee machine refuses to serve drinks).

When level of the Water Container is in low sports, LED of “No Water” will light up and buzzer starts to alarm to awake the owner. (When insert coin or press the drink button at this time, the coin will be return to the customer and the Coffee machine refuses to serve drinks).

How to use the Mineral Water Container

- 1 Lift down the cover of the Water Container.

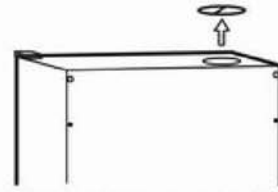

- 2 Put the water bucket onto the interface of the Water Container.

Do not let the elder or children replace the heavy bucket.

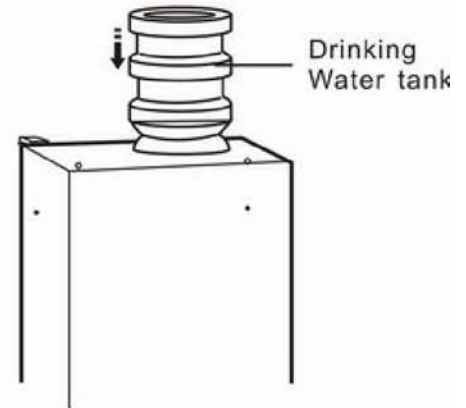

- 3 Interface of Water Container in this machine is specially designed for water bucket.

※ When the water bucket is not on the Water Container, the volume of drink will differ by different water line.



Avoid the water spilling and dripping on the surface of the machine when replacing the mineral water bucket.

Auto-cleaning of Feeding Pipe and Mixing Tank

Please clean the raw material beater and feeding pipe as usual as possible

● Operation for cleaning

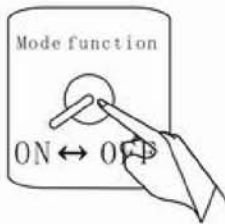

- 1 Turn the Mode Function switch inside the machine to position "ON".
- 2 Press No.2 button on the Panel (It is called No.1,2,3,4,5 buttons from the bottom up)

※ With a vessel receive the cleaned water at the drink outlet. Take care not to burn by hot water.

To clean and sterilize with hot water at least once a day in order to prevent peculiar smell.

How to Place Raw Material

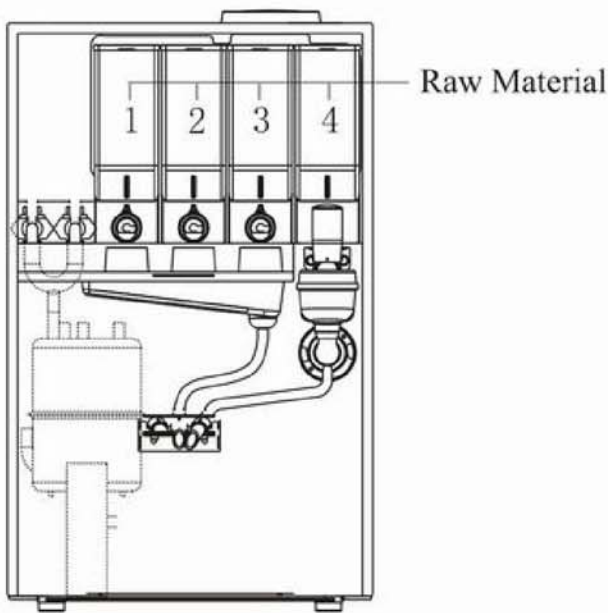

Material Setting Order

Material box	Material name
1	Sugar
2	Cream
3	Coffee
4	Juice

Material Box order: set No.1, 2, 3, 4 material boxes from the left to right

Dismount the raw material box first.

- 1 Rotate the T-shaped muff-joint to the graph 90° along the orientation of the arrow.

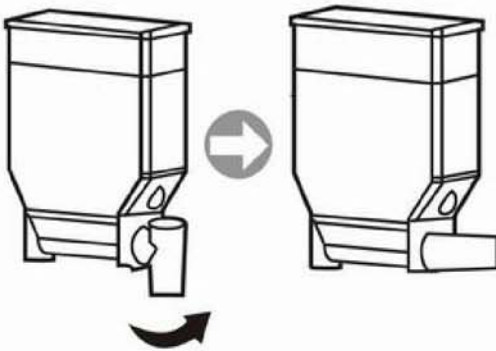

- 2 Lift the front of the box lightly and pull it out.

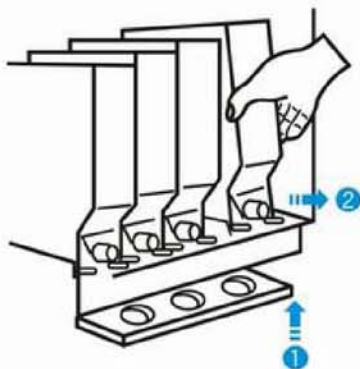

Factory Setting of Raw Material Volume

Drinks	Sugar	Cream	Coffee	Juice
Material Volume	2.5	2.5	1.7	2.5
Water Volume	6.5	6.5	6.5	6.5

How to Fix the Raw Material Bucket

1 Put the holdown groove of raw material bucket shaft in rotation shaft.



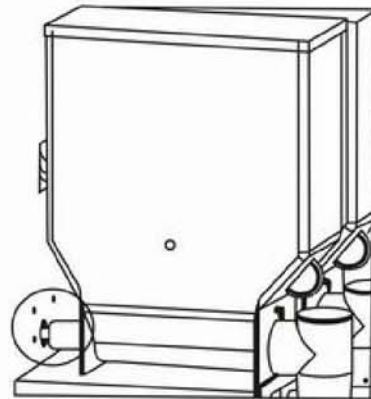

- When feeding material, follow the relevant names of material in the bucket.
- In case of higher humidity please use heating band for prevention of solidification of raw material.
- In case of higher humidity in summer, using the heating band brings higher efficiency, but in winter it brings the reverse effect.



Replacement of Fuse

When the fuse burns off, replace it with a new one(AC250V,10A).
Replacement of the fuse is not included in the after-sale service.

● Replacement of Power Fuse

<p>1 Before replacement pull out the plug</p> 	<p>2 Open the cover of the fuse box.</p> 
<p>3 Take out the fuse and put in the new one.</p> 	<p>4 Screw tight the cover.</p> 

How to place the cups

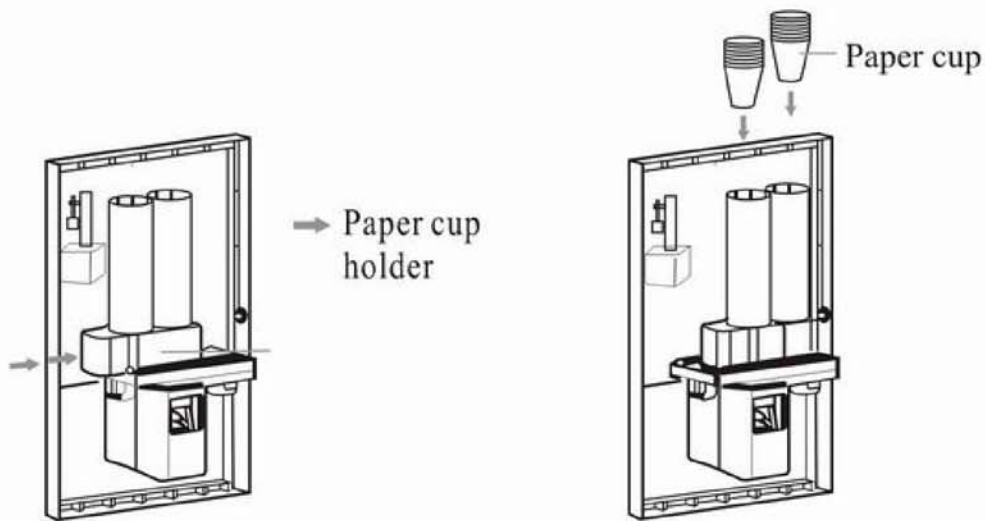

1 The bottom of cup hold must be pushed to the right(see the picture).

2 Push cups into the cup holder pipe.

* When loading cups,put them in by batches, 5-10 cups for one time.

3 Number of cups: 301Ra/Rax-about 55 cups
301RDa/RDax- about 110 cups

4 Press the cup test button and with buzz a cup falls from the outlet.

Cup testing

1 Turn the Mode Function switch inside the machine to position "ON".

2 Press No.3 button on the Panel (It is called No.1,2,3,4,5 buttons from the bottom up)



- Do not use nonstandard, shriveled and moistened cups.
- Do not press cups when putting in to avoid damaging the cup inductor.

Setting and Usage

The Factory Setting for Drink taste is standard state and customer can regulate the taste by different taste.

Setting and choice of Drinks

1 To fill the Water Container.

- Be careful not to watering down on the surface of the machine.
 - Fill 3 / 4 of the Water Container, while there is no water bucket on the Water Container.
-

2 Put the power plug in the socket of 220V.

-  Please use the grounded socket.
(Grounded plug for this machine)
-

3 Turn on the power switch backside of the machine.

With the sound of buzzer, “Be Heating” director lamp lights up.

At this time the water is not hot enough to make the drinks and the coffee machine is in Standby Mode.

About 13~15 minutes later, lamp of “For Use” lights up and the machine is ready for using.

4 Before using, please operate self-checking of the machine (see P. 11) to make sure all the function is in good condition and as well auto-cleaning for mixing tank and feeding pipe (see P.11) to wash and sterilize.

Set the drink unit price. (see P.17)

Furnish the raw material tank and fill with raw material.

Put the cups and check the dropping function of cups (see P.14)

Turn the Mode switch to position “OFF”, put the machine in service.

-  Caution: Mode switch should be turned to position “OFF” before plug in.

Adjustment of Taste and Water Volume

Appreciated taste of drinks can be adjusted by different hobby, and also remembered in the controlling program.

Adjustment of Drink Taste

- 1 Turn the Mode Function switch (inside the machine) to position "ON", the Display shows " ".



- 2 Press SET button (No.4 button on the Panel) 8 times, then the display shows **AN.0** means setting sign for water volume of the first drink (solenoid valve). Customer can adjust appropriate water volume by "INCREASE" and "DECREASE" buttons here.

Press No.4 button again and the Display shows **AN.1** means setting sign for feeding volume of the first electric motor of the first drink. Customer can adjust appropriate raw material volume by "INCREASE" and "DECREASE" buttons here.

Press No.4 button once again and the Display shows **AN.2** means setting sign for feeding volume of the second electric motor of the first drink. Customer can adjust appropriate raw material volume by "INCREASE" and "DECREASE" buttons here.

Press No.4 button once again and the Display shows **AN.3** means setting sign for feeding volume of the second electric motor of the first drink. Customer can adjust appropriate raw material volume by "INCREASE" and "DECREASE" buttons here. (We can pass this operation because this machine only has one feeding electric motor.)

*All the different parameter values mentioned below can be regulated by "INCREASE" and "DECREASE" buttons, and the like.

In the following form, the item which is marked with "O" means should set the parameter, and set zero for the items marked with "X".

Traditional Coffee	AN.0	AN.1	AN.2	AN.3	Original Coffee	AN.0	AN.1	AN.2	AN.3
	○	○	○	○		○	×	×	○
Coffee With Sugar	AN.0	AN.1	AN.2	AN.3	Juice	AN.0	AN.1	AN.2	AN.3
	○	○	×	○		○	○	×	×
Coffee With Cream	AN.0	AN.1	AN.2	AN.3	Factory Setting for material volume (See P. 12)				
	○	×	○	○					

- 3 Having adjusted the taste, the Confirm button should be pressed and the Mode Function switch (inside the machine) turned to position "OFF", Display shows **P.00**



Setting of Unit Price

1 Turn the Mode Function switch (inside the machine) to position “ON”.



Display on the Panel shows “SET”.

Press the “SET” button (No.4 button) on the Panel 3 times.

2 ▶ Display shows — means the unit price for the First kind of drink.

Press the “SET” button on the front board 4 times.

▶ Display shows — means the unit price for the Second kind of drink .

Press the “SET” button (No.4 button) on the Panel 5 times

▶ Display shows — means the unit price for the Third kind of drink.

Press the “SET” button (No.4 button) on the Panel 6 times

▶ Display shows — means the unit price for the Forth kind of drink.

Press the “SET” button (No.4 button) on the Panel 7 times

▶ Display shows — means the unit price for the Fifth kind of drink.

Note: The marshaling sequence of Raw material box in the machine is Raw material 1,2,3 from left to right.

3 Press the “INCREASE” and “DECREASE” buttons to adjust prices

- Customers can adjust up and down by unit of RMB 1, by pressing the “INCREASE” and “DECREASE” buttons on the Panel



4 The Confirm button on Panel should be pressed after the setting is over and the Mode Function switch turned to position “OFF ”(The setting is over).

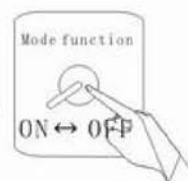

The price of drinks is counted by RMB 1, and can be adjusted from RMB 0 to RMB 99 per cup.



Setting for Water Temperature

Setting for Water Temperature

1 Turn the Mode Function switch (inside the machine) to position "ON". The Display shows "SEI".

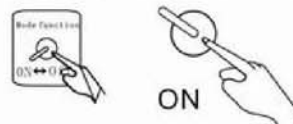

2 Press No.4 button once, the Display will show H.93 , Means upper limit temperature (The customer can adjust the temperature by "INCREASE" and "DECREASE" buttons here.)

The highest temperature can reach 93 degrees Celsius, the lowest for normal temperature. by pressing the INCREASE and DECREASE buttons to set the upper limit water temperature.

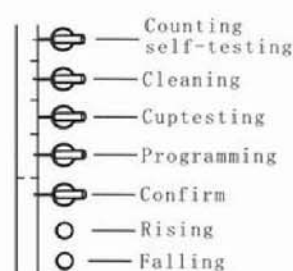

3 Press No.4 button once again, the display will show L.85 means lower limit which can be set here by pressing INCREASE and DECREASE.

We advise to customers that the lower limit temperature of hot drinks should be set higher than 80 degrees Celsius. The factory setting of temperature is 90 degrees Celsius for upper limit and 85 degrees Celsius for lower limit.



4 The confirm button on the Panel of front door should be pressed after the setting is over and the Mode Function switch should be set to "OFF", the display shows P.00 .



The temperature of hot water can be adjusted from 85 to 93 degrees Celsius and you can set different temperatures by season.

Summer: 83 ~ 88 degrees Celsius Spring & Autumn: 84 ~ 89 degrees Celsius

Winter: 85 ~ 90 degrees Celsius

* The factory setting is in a difference by season , the customer can adjust by need.

Sales Quantity Confirmation function

The sales quantity can be confirmed in the following way.

1 Turn the mode function switch (inside the machine) to position “ON”.

The Display shows “SEI”.



2 Press No.1 button twice until the sales quantity for the first kind of drinks displays. The Display shows **1.00** first, about 2 second later it shows **000** and returns to **1.00**

shows the first kind of drink
the fifth figure of the number of quantity
the forth figure of the number of quantity

the third figure of the number of quantity
the second figure of the number of quantity
the first figure of the number of quantity

Ex: If some kind of drink is sold 23263 cups and now you want to confirm the sales quantity. Whil “SEI” is displayed press No.1 button twice and then the Display will show **1.23** for two seconds and follow to show **263**.

When press No.1 button 3 times, sales quantity for second kind of drink will be displayed.

When press No.1 button 4 times, sales quantity for third kind of drink will be displayed.

... ..

The rest may be deduced by analogy.

3 To clear the sales quantity

When the Display shows sales quantity, press the ⊕ or ⊖ button for 3~4 seconds.

4 Turn the Mode Function switch to position “OFF”.(The confirmation is over).



Defect Confirmation

Phenomena and Confirmation

Does not start:



Is the plug inserted?
Be sure the power is 220V.
Is the fuse broken?
Contact the service center
and replace it with a new
one.

Raw material solidifies:



Is the machine not in work
for a long time? Pull out the
plug and clean the material
bucket.
Does not the exhausting
motor work due to foreign
matter?
If the exhaust fan does not
work and humid in the ma-
chine can not be removed,
please clean the exhaust
pipe

Paper cup does not come out:

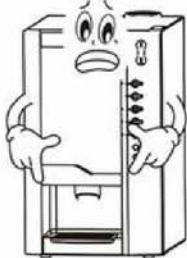

Did you use non-standard,
moistened or deformed cup?
Remove the cup and place new ones.
Are the cups in good order?
Put the hand inside the mouth
of cup and push it upwards.

Alien noise:

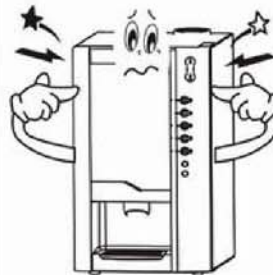

Is the machine placed on
slanting or uneven floor?
Place the machine on the
horizontal and even floor.
Does the exhaust pipe
have impurities and noise?
--Clean the pipe.
If there is the sound of
boiling?
--In order to keep the
water temperature the
heater is repeatedly
started.

Drink does not flow out smoothly:

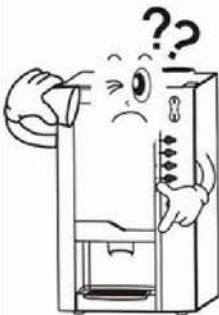

- Are particles or is sticky material used?
- Use only designated material.
- Is the material in the tank solidified?
- Dismantle the tank and clean it.
- Is the tank placed in the former position?
- Are the raw coffee mixer and tea passage stopped up?
- Clean the mixer and passage.
- Is the material in the tank used up?
- Fill in the material.

Strong alien taste:



Is the water in the water box
long time?
—Pour out the water in the box
and clean it.
• Did you clean the inside of the
machine periodically?
• Did you not use the machine long
time?
—Pull out the power plug and
remove material and clean the
machine.

Dismantling of Parts

Dismantling of coffee material mixer

- 1 Pull up the top of the mixer and pull it out.
- 2 Turn the bottom of mixer clockwise and pull it out forward.

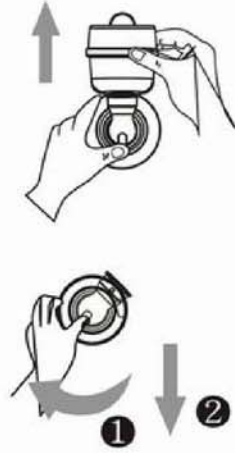

Dismantling of Water Tank

- 1 Pull out the soft hose and pull out the tap.
 - Remove all the water in the tank.
 - Turn off the power.
 - Take care against hot water.
- 2 Dismount the back cover with a crossdriver.
- 3 Pull out the hose of the tank.
- 4 Pull out the water tank.

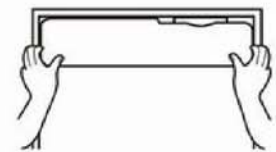
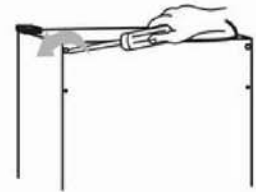

Caution: Just after beginning of water removal, the temperature is very high and you must be careful.



Dismantling of the cover of fan

Caution: Turn off the power and dismantle the fan. Rotate the right knob and pull it out.

*When removing humid in the machine the powder moistened raw material will contaminate the fan cover and the exhaust fan and it is necessary the clean frequently.

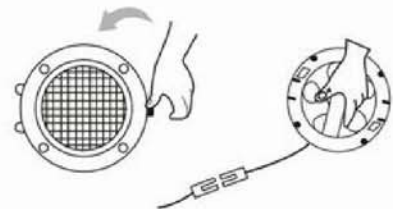

Cleaning

The raw material powder will fall and solidify inside the machine and the water on the receptacle is accumulated for long time and it causes a foreign taste and not Hygienic and therefore frequent cleaning is necessary. Pull out the plug before cleaning.

- Do not clean with chemicals such as benzene and zinc thinner.

* Water tank

Clean the inside spots of machine with soft sponge paper. Clean over 2 times per month.



* Raw Material Bucket

Soak in water to solve the solidified material and clean it with soft sponge. Assemble after drying. Humid make material solidify and feeding be unsmooth. Clean over one time per month (or whenever material solidifies).



* Water Receiving Box

Pour out the accumulated water within the receptacle and soak in water and clean.

- After drying put it in the former position. Clean once every day.



* Coffee Material Mixer

Soak it in water and clean it with a soft brush.

- After cleaning put it into the former place. Clean it once every day.



* Cup Hole

Clean it with wet cloth.

- Wipe water with dry cloth. Clean it once every day.



* Fan Cover in the Exhaust Hole

Soak it in water and wash the powder and dust of material and dry it.



* Exhaust Fan

Remove powder and dust of material with a brush and clean it with wet cloth.

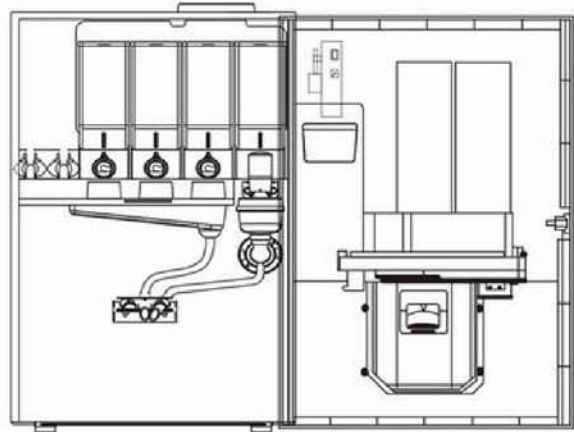

MEMO

Notice for customers

Please insert RMB 1 coin when the unit price of drinks is set to zero. Because computer inside machine is set to give order to supply the drinks only when it recognizes the coin inserted. The information of RMB 1 coin inserted at when the unite price of drinks is set to zero will be recorded in the computer.

Parameter List for discharge

Coffee		Orange Juice		Lemon	
Discharge Parameter	Weight (g)	Discharge Parameter	Weight (g)	Discharge Parameter	Weight (g)
A5.0	12.5	A5.0	13.6	A5.0	15.6
A5.5	13.6	A5.5	15.0	A5.5	17.7
A6.0	14.7	A6.0	16.2	A6.0	19.1
A6.5	15.6	A6.5	17.5	A6.5	21.0
A7.0	17.0	A7.0	18.7	A7.0	22.0
A7.5	18.4	A7.5	19.7	A7.5	23.9
A8.0	19.5	A8.0	21.0	A8.0	24.2
A8.5	20.7	A8.5	22.5	A8.5	26.0
A9.0	21.9	A9.0	23.3	A9.0	27.8
A9.5	23.0	A9.5	24.7	A9.5	29.4

(Above data is only for reference)